

INTERGOVERNMENTAL
OCEANOGRAPHIC
COMMISSION



12220
WORLD
METEOROLOGICAL
ORGANIZATION



Manuals and Guides

GUIDE TO OPERATIONAL
PROCEDURES FOR THE
COLLECTION AND EXCHANGE
OF OCEANOGRAPHIC DATA
(BATHY AND TESAC)

The preparation of this revised version of Guide N° 3 is described in document IOC-WMO/IGOSS-III/8 "Action Paper", item 3.4. This revised version is submitted to the JWC for approval before it is published.

PREFACE

All nations are profoundly influenced by the world oceans in many ways - some direct and obvious, others indirect and more subtle. Even those countries without ocean coastline feel the influence of the ocean, for example, as it affects world-wide weather and climate and in the availability of foreign goods and access to distant markets. Some influences of the ocean are beneficial; others may be detrimental to human activities; most are beyond our ability to control, except in very limited ways, but, forewarned with a knowledge of the state of the ocean and even a limited prediction of future trends, it may often be possible to maximize the beneficial effects and to avoid or guard effectively against those which could be detrimental.

The Integrated Global Ocean Services System (IGOSS) was conceived as a means to collect and exchange oceanic data in such a form that they can be readily interpreted and applied to practical problems. Data in various forms may be gathered from many sources. It is necessary to properly encode and route these data to processing centers using proper quality control procedures. It is then possible to prepare products which summarize and/or interpret the data in ways which are meaningful and useful to users. Finally, the products are distributed to users and the data are stored or "archived" for future use. The IGOSS system has been designed to carry out these functions in co-operation with other international agencies.

It would be appropriate to recall that IGOSS consists of three essential elements through which the above activities are carried out. These elements are:

- (i) The IGOSS Observing System (IOS) consisting of various facilities and arrangements for obtaining standardized oceanographic information from voluntary observing ships, research ships, ocean weather stations, fixed and drifting buoys, aircraft and other platforms;
- (ii) The IGOSS Data Processing and Services System (IDPSS) consisting of national, specialized and world oceanographic centres, for the processing of observational data and the provision of products and services to marine user groups and for data archiving and exchange activities; and
- (iii) The IGOSS Telecommunication Arrangements (ITA) consisting of telecommunication facilities of the World Weather Watch (WWW) Global Telecommunication System (GTS) and other arrangements necessary for the rapid and reliable collection and distribution of the required observational data and processed information.

This document is intended as a general guide to the operational procedures for the collection, encoding, quality control and exchange of oceanic surface and sub-surface temperature, salinity and current (BATHY and TESAC) data. It is anticipated that individual nations will issue specific guidelines within the framework of this document. In all cases, it should be recalled that the overall objective of IGOSS is the timely collection and exchange of oceanic data and products. Therefore, proper procedures and precautions must be exercised at all times by participants in the programme.

This edition of the Manuals and Guides No.3 replaces the 1975 edition.

TABLE OF CONTENTS

1. INTRODUCTION
 - 1.1 General
 - 1.2 Definition of terms
2. DATA COLLECTION
 - 2.1 Parameters involved
 - 2.2 Instrumentation
 - 2.3 Platforms
 - 2.4 Observational strategy
3. DATA ENCODING
4. DATA ROUTING
 - 4.1 General data flow
 - 4.2 Platform to shore transmission
 - 4.3 National routing arrangements
 - 4.4 International routing arrangements
 - 4.5 Operational data dissemination
 - 4.6 Non-operational routing of BATHY and TESAC data
5. ERROR CHECKING AND QUALITY CONTROL
 - 5.1 Introduction
 - 5.2 Steps to improve data quality at its origin
 - 5.3 Quality control procedures before insertion onto the GTS
 - 5.4 Quality control procedures after reception from the GTS
6. MONITORING
 - 6.1 General
 - 6.2 National monitoring
 - 6.3 Monthly exchange
 - 6.4 Periodic GTS monitoring

ANNEXES

- ANNEX I - Instructions for preparing the "BATHY" log
ANNEX II - Instructions for preparing the "TESAC" log

- ANNEX III - Simplified layout of a BATHY or TESAC message exchanged over the GTS
 - ANNEX IV - Example of a BATHY message exchanged over the GTS
 - ANNEX V - Minimum quality control procedures for IGOSS data to be transmitted over the GTS
 - ANNEX VI - Minimum quality control procedures for IGOSS data taken from the GTS
 - ANNEX VII - Guidelines for reporting monthly BATHY/TESAC statistics
 - ANNEX VIII - List of abbreviations
-

1. INTRODUCTION

1.1 General

1.1.1 The Integrated Global Ocean Services System (IGOSS) is the international operational oceanic system for the global collection and exchange of oceanic data and the timely preparation and dissemination of oceanic products and services. The Intergovernmental Oceanographic Commission (IOC) and the World Meteorological Organization (WMO) co-operate in the planning and implementation of IGOSS. The operation of IGOSS is based on national contributions and depends on the full support of all IOC and WMO Member States. The timely dissemination of data and/or products depends on the facilities of the Global Telecommunication System (GTS) of the World Weather Watch (WWW) of the WMO.

1.1.2 The programme for the collection and exchange of BATHY and TESAC data was initiated as a pilot project on 15 January 1972 and became fully operational in June 1975 as the BATHY/TESAC Operational Programme. It involves the global collection and exchange of ocean temperature, salinity and current data observed from merchant ships, research vessels, Ocean Weather Stations (OWS), ocean data buoys, offshore platforms, coastal stations and aircraft. The incorporation of new technological developments will permit fuller implementation of this programme.

1.1.3 This Guide describes the operational procedures for the BATHY/TESAC Operational Programme. The instructions and guidelines to be followed are arranged under the following main headings:

- Data collection
- Data encoding
- Data routing
- Error checking and quality control
- Monitoring

1.2 Definition of terms

A number of terms are used in this Guide with a meaning unique to IGOSS and may cause some confusion for meteorologists, oceanographers and data specialists. Working definitions of these terms are given below.

Operational data

1.2.1 Data up to 30 days old from the time of observation. Operational data should be exchanged on the GTS.

Non-operational data

1.2.2 Data older than 30 days. Non-operational data should not be exchanged on the GTS.

Timely

1.2.3 Within a space of time since the time of observation such that the data are of operational use. The duration of the timely period depends essentially on the physical phenomenon under consideration. For IGOSS purposes that duration goes from one or two days up to 30 days.

Oceanographic products

1.2.4 Any analysis, forecast or summary of oceanographic conditions prepared and disseminated to meet the need of governmental, commercial, academic or private user groups. IGOSS service products include: Analysis, forecasts and summaries for such parameters as sea surface temperatures and their anomalies, sub-surface temperatures, mixed layer depth, ocean frontal position, current and salinity.

Operational products

1.2.5 Products prepared to reach the user in a timely fashion and produced on a regular basis for more than a year. These products are usually produced through the IGOSS Data Processing and Services System (IDPSS).

Report

1.2.6 Observation encoded in appropriate code form and transmitted to shore stations (BATHY reports are in WMO code form FM 63-VI and TESAC reports are in WMO code form FM 64-VI). Reports are then forwarded through national channels to a GTS input point where they are gathered into GTS bulletins.

Radio messages

1.2.7 A message radio transmitted from the platform to a shore receiving station and containing: (i) The abbreviation OBS; (ii) The radio address of a meteorological or oceanographic centre; (iii) The report; (iv) Any other information prescribed by radiotelecommunications procedures.

2. DATA COLLECTION

2.1 Parameters involved

The primary parameters to be observed within the framework of IGOSS are

those which are relevant for the physical description of the state of the ocean and which can be measured on a routine basis. Therefore, the BATHY/TESAC Operational Programme deals with temperature, salinity and currents. In addition, other environmental parameters may be useful in order to interpret the data.

Temperature

2.1.1 Knowledge of the thermal structure of the upper layers of the ocean is essential in order to understand heat transfer between the atmosphere and the sea and heat transport in the ocean. In addition, the knowledge of the thermal structure is needed for applications in fisheries and climate analysis.

Salinity

2.1.2 Sea surface salinity is important in order to determine water mass movement, circulation and frontal activity. Sub-surface salinity structure together with sub-surface temperature structure are useful for calculating geostrophic currents. It is also pertinent to the behaviour of the mixed layer.

Currents

2.1.3 Currents are the main process through which heat is transferred from one zone of the world to another and is a critical item in climate studies. Regular current monitoring is also of great value for such practical purposes as ship routing.

2.2 Instrumentation

The instruments used for measuring temperature, salinity and current are:

2.2.1 For temperature versus depth:

- Mechanical Bathythermographs (BT)
- Expendable Bathythermographs (XBT)
- Airborne Expendable Bathythermographs (AXBt)
- Thermistor chains
- Reversing thermometers.

2.2.2 For temperature and salinity versus depth:

- Hydrocasts
- Conductivity-Temperature-Depth instruments (CTD)
- Salinity-Temperature-Depth instruments (STD)
- Expendable CTD/STD (XCTD, XSTD).

2.2.3 For sea surface current:

- GEK (Geomagnetic Electrokinetograph)
- Acoustic Doppler devices

- Ship's set and drift
- Drifting buoys.

2.2.4 For current versus depth:
- Moored current meters.

2.3 Platforms

Ships

2.3.1 Ships remain the most valuable means of oceanographic data gathering. Three types of ships are commonly used for this purpose:

- (i) Merchant ships are of major importance for the IGOSS Observing System and are encouraged to observe oceanic parameters by participating in the IGOSS ships-of-opportunity programme and in the WMO Voluntary Observing Ships (VOS) scheme;
- (ii) Research vessels continue to be a prime element for the IGOSS Observing System because of the versatility, dependability and accuracy of their observations and despite the fact that their number is relatively small and their operating costs are increasing rapidly;
- (iii) Ocean Station Vessels (OSV) assigned to the Ocean Weather Stations (OWS) have provided high quality time series measurements of oceanographic parameters at fixed points and are important for the calibration and verification of satellite and ship data.

Buoys

2.3.2 Both moored and drifting buoys have proved to be useful for oceanic data gathering. Member States should make particular efforts to develop reliable automatic systems capable of producing information on sub-surface parameters in the ocean environment.

Aircraft

2.3.3 Aircraft are used for the deployment of airborne expendable bathy-thermographs and for the recording of measurements.

Other platforms

2.3.4 Coastal stations and offshore platforms should be considered part of the IGOSS Observing System as far as they provide IGOSS data. In particular, countries and/or firms operating offshore platforms are encouraged

to carry out regular measurements of oceanic parameters in order to provide calibration values and dependable time series.

2.4 Observational strategy

Data requirements

2.4.1 The requirements for observations by the IGOSS Observing System are determined by three scales of interest:

- (i) The largest of these scales is the ocean basin scale wherein observations are needed to investigate or describe large, planetary-type phenomena or motions occurring in ocean basins;
- (ii) Regional requirements are directly linked to more detailed investigation of planetary motions and the preparation of corresponding products. These requirements will arise from co-operative regional programmes by two or more participating Member States;
- (iii) Finally, there are requirements on a national or local scale that are dictated by the scientific, economic and industrial requirements of the individual state. These requirements will vary greatly from country to country and will undoubtedly interact with the other two categories.

Space/time sampling frequency

2.4.2 The frequency and spacing of observations under IGOSS must be adjusted to suit the physical scales of the oceanographic phenomena to be described. The following classification of scales of oceanographic phenomena are considered under IGOSS:

<u>Scale</u>	<u>Horizontal</u>	<u>Vertical</u>	<u>Temporal</u>
(a) Meso-scale	10 to 100 km	1 to 100 m	hours to week
(b) Large scale	100 to 1000 km	100 to 1000 m	week to months
(c) Planetary scale	greater than 1000 km	total depth	months to years

Although the scales indicate the minimum sampling rates to describe the process, higher sampling rates in space and time may be required to prevent aliasing. In general terms, fixed stations such as weather ships, buoys, etc. should take observations at least four times per day and it is desirable that mobile ships take measurements two times per day or at approximately 200 km interval. More precise specification of observational programmes should be determined by the operating agency or institution. Apart from the requirement for a world-

wide distribution of oceanographic data there is a strong demand for "repeated data" from the same area through seasonal or annual cycles. Repeated sections can be achieved, for example, by means of merchant ships on routine tracks.

3. DATA ENCODING

The log forms are designed to achieve two purposes, namely: to provide a means for formatting the report as a ship-to-shore radio message and as a medium to prepare the data for further use. Both BATHY and TESAC logs are divided into four parts:

Part I - Cruise information:

Includes the information concerning the cruise and the country or institution sponsoring the cruise. This information is necessary only once for a cruise.

Part II - Radio message information:

Contains all information to be transmitted.

Part III - Station and reference information:

Consists of the information needed to identify a given station and makes provision for entering reference measurements for checking or calibrating the instrument.

Part IV - Environmental information (optional):

Provides additional information which is helpful for further processing of the data.

Detailed instructions on how to complete the BATHY and TESAC log forms are contained in Annexes I and II respectively.

4. DATA ROUTING

4.1 General data flow

4.1.1 IGOSS data which do not need subsequent processing enter the dissemination system in two ways:

- (i) As operational messages via a coastal radio station to a National Oceanographic Data Centre (NOC) or a National Meteorological Centre (NMC) and a Regional Telecommunication Hub (RTH); and
- (ii) As completed log forms, or other raw data, via a national oceanographic agency through the normal International Oceanographic Data Exchange (IODE) procedures.

4.1.2 Data which need some subsequent processing, such as data from operational satellites and satellite communicated data from moored and drifting buoys and bottom moorings, pass through and are processed by satellite receiving centres. The processed data then enter the system in two ways:

- (i) As operational data via a NOC or NMC and a RTH;
- (ii) As non-operational data with all available additional information - delivered on magnetic tape - via National Oceanographic Data Centres (NODCs) through the data exchange system of the IODE.

4.1.3 To provide the user the data within operational time as well as to provide long-time archiving, the data flow is separated into two components as the figure below shows:

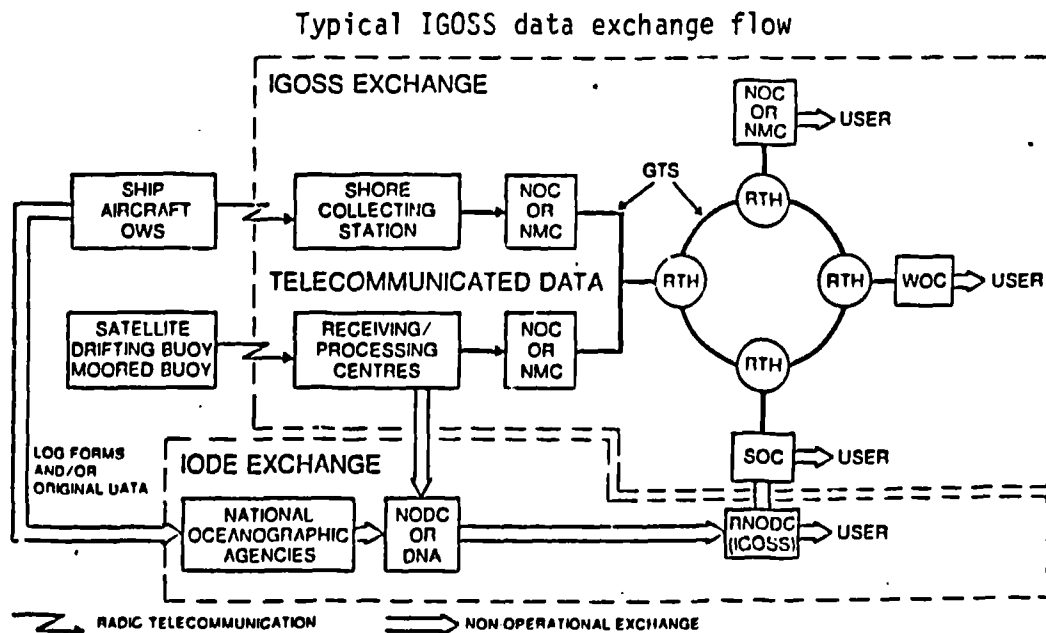

- (i) An operational data flow for which IGOSS is responsible. This data flow contains, in general, that information which has been radio-transmitted. The time frame in which the data set is available for IGOSS activities extends from one day to less than two months. The quality control procedures applied to these data are described in

Chapter 5. The operational data set is also forwarded to IODE's RNODCs which provide long-term storage; and

- (ii) A non-operational data flow for which IODE is responsible. This data flow contains detailed identification information and other supporting environmental data as well as the basic oceanographic data.

4.1.4 The collection and exchange of operational BATHY and TESAC data involves the following four stages:

- Platform to shore transmission
- National routing arrangements
- International routing arrangements
- Operational data dissemination.

4.2 Platform to shore transmission

General

4.2.1 The platform to shore transmission concerns the forwarding of data from the platform to a National Oceanographic Centre (NOC) or a National Meteorological Centre (NMC) via a shore collecting centre. At the present time this transmission is largely based on the International Maritime Mobile Service (IMMS). Watch-keeping hours aboard ships and the increasing traffic in this Service, especially in HF communications, have been two of the main areas of difficulty affecting the timely and efficient collection of ships' reports. It is therefore important that new telecommunication capabilities such as those offered by radiotelex and the satellite data collection system be fully utilized. The following paragraphs describe primarily the procedures applicable to the transmission from platform to shore collecting centres using the IMMS.

Completion of radio messages

4.2.2 The BATHY or TESAC report consists of Part II of the completed log form. After careful checking (see below Chapter 5), it is submitted to the radio officer who is responsible for transmitting it to a shore station. He must select the most appropriate coastal radio receiving station (see paragraph 4.2.5 below) and insert the radio address of the message. The abbreviation OBS shall be included as a paid service indicator before the address to secure the appropriate priority handling of reports by coastal radio stations.

Time and delay of transmission

4.2.3 The reports should be transmitted as soon as possible after the time of observation. However, the reports may be transmitted up to 48 hours after the time of observation in case operational difficulties preclude their earlier transmission. Nevertheless, in order not to interfere with the transmission of meteorological reports it is recommended to avoid, as far as possible, the following regularly scheduled meteorological transmission periods:

- 23.30 GMT - 02.00 GMT
- 05.30 GMT - 08.00 GMT
- 11.30 GMT - 14.00 GMT
- 18.30 GMT - 20.00 GMT

Submission of late reports

4.2.4 Many BATHY and TESAC reports which were not telecommunicated may be collected after the return of the ship to port. The operators are encouraged to forward the data to the appropriate national agency as soon as practicable for insertion onto the GTS.

Receiving stations

4.2.5 BATHY and TESAC reports should be transmitted to addresses specified nationally or to one of the METEO addresses listed in WMO Publication No. 9, Vol. D, Part B: "Coastal radio stations accepting ships' weather reports", via one of the coastal radio stations listed in the same publication. METEO addresses accepting BATHY and/or TESAC reports are indicated as "BATHY/TESAC" in column "Remarks" of the listed stations and the principles of choosing the radio receiving station are detailed at the beginning of the afore-mentioned publication. In general, the national co-ordinator for the IGOSS BATHY/TESAC Operational Programme will provide the platform operators with a list of appropriate coastal radio stations within the area where the platform is operating.

Use of new telecommunication capabilities

4.2.6 The use of semi-automated or automated transmission devices onboard platforms is continuously increasing. These include those employed in the International Maritime Satellite System (INMARSAT), environmental satellites DCPs and Service Argos. Specific procedures for data transmission are determined by the particular system in use. In all cases, the objective remains to transfer observational data from the platform to the appropriate NMC or NOC for insertion onto the GTS as rapidly and as error-free as possible. Ships may not have a radio officer onboard when the ship is very close to the coast. In such a case the radiotelephone may be used for the transmission of ship messages to the NMC or NOC concerned.

4.3 National routing arrangements

4.3.1 The national arrangements for the routing of BATHY and TESAC observations fall under the responsibility of the country in which the shore collecting station is located. In principle, this part of the routing can be envisioned as follows:

4.3.2 The radio messages sent from platform to shore contain the address of the NMC or NOC to which they are to be forwarded from the shore collecting station. If the NOC and the NMC are not co-located the NOC should ensure the relay of reports to the NMC.

4.3.3 The NMC is usually responsible for the collection of oceanographic reports received by centres located in its area of responsibility and for their transmission to the associated RTH of the GTS and WMC. The NMC is also responsible for checking and correcting reports to ensure that standard telecommunication procedures are applied. The NMC acts therefore as the GTS centre responsible for compiling individual reports into bulletins (see below paragraph 4.4.3). It is recommended that bulletins be compiled at least every 12 hours or as they become available. They may contain reports from several ships and various observation times. BATHY and TESAC observations should be compiled in separate bulletins.

4.3.4. WMO Members operating those GTS centres which insert oceanographic reports onto the GTS should provide the WMO Secretariat with the transmission schedules and TTAAii group and request, if required, the allocation of appropriate CLLLL numbers for oceanographic data (see Annex III).

4.4 International routing arrangements

4.4.1 The exchange programme of BATHY and TESAC observations over the GTS is based on the decision of the WMO Executive Committee and the Commission for Basic Systems (CBS) that the WMO regional associations make suitable arrangements for the exchange of these data in their regions. It has, however, become necessary to widen the scope to include interregional and global exchanges taking into account the increasing requirements for the exchange of oceanographic data.

4.4.2 On the basis of requirements expressed by the Members a plan for the routing of the BATHY and TESAC messages has been prepared by the WMO Secretariat. The basic principles followed in establishing this plan are:

- (i) These messages are exchanged globally on the Main Trunk Circuit (MTC) and its branches. Since the MTC and its branches are fully operational all WMCs and RTHs located on the MTC and its branches receive and transmit BATHY and TESAC messages in accordance with stated requirements;
- (ii) The WMO standard telecommunication procedures specified in the Manual on the Global Telecommunication System (WMO-No. 386) apply to BATHY and TESAC bulletins;
- (iii) The national Meteorological Services operating NMCs as GTS centres are the responsible parties for the international exchange of BATHY and TESAC messages.

4.4.3 Only messages formatted in accordance with the rules enacted in the Manual on the GTS may be routed on the GTS:

- (i) Each message is composed of a starting line, one bulletin and an end-of-message signal;
- (ii) A bulletin is composed of an abbreviated heading followed by a set of (BATHY or TESAC) reports each separated by a report separation signal;
- (iii) The reports have already been defined.

Annex III shows the layout of a BATHY or TESAC message as it must be compiled for exchange through the GTS. Annex IV gives an example of such a message and explains how to decode it.

4.5 Operational data dissemination

4.5.1 The NMC which is the terminal point of the GTS for the receipt of data disseminated over the GTS is responsible for receiving the oceanographic reports and forwarding them to oceanographic and meteorological centres involved in the preparation of products. The routing arrangements in this phase should be established on a national basis.

4.5.2 Requirements for the operational receipt of BATHY and TESAC data should be directed to and consolidated by the national Meteorological Service which operates the NMC as a GTS centre. These requirements are to be further submitted to the WMO Secretariat to ensure the co-ordination of routing arrangements, in consultation with appropriate WMO bodies, for implementation by Members concerned.

4.6 Non-operational routing of BATHY and TESAC data

4.6.1 The international data exchange and archiving of BATHY and TESAC data in non-real-time falls under the responsibility of the International Oceanographic Data Exchange (IODE) system of IOC. The Manual on IGOSS Data Archiving and Exchange (IOC Manuals and Guides No. 1) stipulates the procedures to be followed. As the original data records and the log forms are to be submitted observers should strive to label records correctly.

4.6.2 After return to port, the completed log forms and the original traces will be forwarded to the national oceanographic agency in charge of collecting these data. The actual channels through which the data are routed before entering the IODE system vary from country to country.

5. ERROR CHECKING AND QUALITY CONTROL

5.1 Introduction

5.1.1 The value of IGOSS data for a user depends essentially upon the quality of the data. In this context, quality is meant in terms of accuracy and reliability which concerns the physical content of a measurement as well as in terms of correct encoding of the value measured.

5.1.2 Several studies have shown that a high percentage of BATHY and TESAC reports still contain errors that can be easily corrected. These errors are the ones that are possible to detect by examination of a telecommunicated data set without the benefit of the original data. Thus, such subtle errors as those arising from minor instrument malfunctions or miscalibration, poor choices of inflection points by the observer or inaccurate reading techniques are not considered in this classification. The following are definitions of different types of errors which will be used in this text.

Message format errors

5.1.3 Message format errors are those errors which concern the starting line of a message, the abbreviated heading of a bulletin and the end-of message signal.

Coding errors

5.1.4 Coding errors are those errors which concern the internationally agreed code forms for BATHY or TESAC reports. These are errors in the position or

content of those fields or characters which are used to indicate the type, origin and content of the report as opposed to errors in the physical values in the report.

Physical errors

5.1.5 Physical errors concern the measured or observed values themselves, e.g. date/time of observation, position, depth, temperature, salinity, current and wind speed, wind direction, air temperature.

5.1.6 At any stage within the data exchange scheme errors may creep into a report, therefore quality control procedures should be applied to the IGOSS data at the following three stages:

- Onboard ship
- At an NMC (or NOC) before insertion onto the GTS
- At an SOC (or NOC) after reception from the GTS.

5.2 Steps to improve the data quality at its origin

5.2.1 Errors begin with the instrumentation. The accuracy of the instrument, its calibration and the operational limitations, e.g. depth or the speed of the ship have to be considered. In this context reference is made to the IOC Manuals and Guides No. 4 - Guide to Oceanographic and Marine Meteorological Instruments and Observing Practices.

5.2.2 Crude or subtle errors introduced by such factors as malfunctioning temperature thermistors, recorder response and uncalibrated thermometers are very often difficult to detect from isolated stations. Also the spike induced by insulation punctures along the launcher probe connecting wire sometimes looks real.

5.2.3 The proper training in the use and maintenance of ocean instrumentation, particularly the instrumentation used onboard voluntary observing ships, is an important factor in the improvement of data quality.

5.2.4 The most significant category of errors is introduced when coding and transmitting the BATHY and TESAC reports. In order to reduce these errors, instructions set out in Annex I and Annex II should be strictly followed. A carefully designed log form written in the mothertongue of the nation concerned is an essential help to avoid errors in coding.

5.2.5 Direct discussion of the programme between the ship's crew and a national authority will lead to closer identification with the value and importance of the IGOSS programme. Feedback of results and expressions of appreciation are some of the best means of ensuring high quality BATHY and TESAC reports from the observing ship.

5.2.6 Several types of automated systems have been developed. These systems automatically format and transmit data through highly reliable satellite systems. Therefore, they will no doubt be the best way to minimize data quality problems arising from manual interpretation, coding and transmission.

5.3 Quality control procedures before insertion onto the GTS

5.3.1 IGOSS reports are inserted onto the GTS by NMCs or, as an exception, by NOCs which have access to the GTS via an NMC. The data arriving at NMCs contain various errors some of which are easily detected and identified and, therefore, can be corrected. However, at this stage, primarily coding errors can be corrected. The data resides at NMCs for only a short time so that correction procedures are best carried out operationally on a computer. However, limited manual corrections can be carried out where data quantity is not large. It is therefore recommended that the minimum set of correction procedures intended for this purpose (see Annex V) should be applied to BATHY and TESAC reports at an NMC (or at an NOC on behalf of an NMC) before the data are inserted onto the GTS. It is anticipated that centres will expand upon this minimum set as they gain in quality control experience.

5.3.2 When compiling bulletins and preparing messages, special attention should be given to the following message format errors which are frequently observed:

- The catalogue number does not agree with the abbreviated heading of the bulletin. C must be 1 and L₃ must be 7;
- TT must be S0. If it is not, most centres cannot retrieve the bulletin and it will be "lost";
- A₁A₂ are incorrect. Country codes (WMO-No. 386, Attachment II-6, Table B) should not be used; Table C (same reference) should be followed. The position of the observation is not within the region designated by A₂; X should not be used habitually for A₂;
- ii conflicts with C in catalogue number. For IGOSS bulletins ii should be in the range 1-19 inclusive for global distribution according to the Manual on the GTS (WMO-No. 386, Part II, 2.3.2.2);

- YYGGgg is incorrect. This should be the time the bulletin is compiled at the GTS centre for exchange. It has been noted that this time is indicated occasionally as being prior to the time of the observation of the reports in the bulletin;
- BBB used incorrectly. The use of RTD is reserved for delayed information but has been used for overflow bulletins at the same time as the normal bulletin.

5.4 Quality control procedures after reception from GTS

5.4.1 The further quality control of IGOSS data is necessary after reception of the message from the GTS to ensure the accuracy of operational products and to provide archival centres with uniform quality-controlled data sets.

5.4.2 Quality control procedures at this point in the system should include checks for message format, coding and physical errors. Data which are found to be erroneous or highly suspect should be corrected when the changes can be made with a high degree of confidence. Otherwise the data should be flagged as probably erroneous and not modified. Flags are to be provided for all reported physical variables including position, date, time and depth. Seven flags are provided, the use of which is described in Annex VI. The flags are considered necessary to provide users with information and results of quality control operations and to document any changes made to physical variables.

5.4.3 Reports in which any of the mandatory fields, i.e. latitude, longitude, date and time are missing, should be deleted.

5.4.4 Quality control checks in Annex VI should be considered to be a minimum set of checks. Users are encouraged to apply additional checks where appropriate and possible. Examples of further quality control would include checks of values against climatology or position against a land-sea grid.

6. MONITORING

6.1 General

The exchange of IGOSS reports is monitored in three ways. Exchange of national data is monitored at the national level. International exchange is monitored on a broad statistical basis through examination of monthly input/

output figures submitted by Members. Finally, detailed examination of the GTS exchange is periodically carried out in conjunction with other GTS monitoring survey within the World Weather Watch.

6.2 National monitoring

Since reports come from a variety of platforms without fixed positions or observation times, it is important that a close watch be maintained on the entire process of exchange to avoid interruptions in data flow due to errors in formatting or routing. It is a national responsibility to assure that all observations destined for international exchange are collected, correctly formatted and exchanged via the GTS in a timely manner. This can only be accomplished through an adequate national monitoring programme.

6.3 Monthly exchange

The monthly summaries of the number of BATHY and TESAC reports inserted onto the GTS (INPUT) and extracted from the GTS (OUTPUT) are submitted by national meteorological or oceanographic centres. An example of the monthly statistical summary with an explanation for completion is given in Annex VII. These summaries are analyzed to identify data exchange problems, particularly inconsistencies among centres. The centre where the apparent problem occurs is then alerted to the nature of the problem and a solution is sought.

6.4 Periodic GTS monitoring

The periodic GTS monitoring is used to determine the efficiency of the BATHY and TESAC exchange and to identify discrepancies observed at different centres. The actual message transcripts at several centres are compared. One of the major causes of data loss is errors in formatting the GTS messages (see paragraph 5.3).

INSTRUCTIONS FOR PREPARING THE "BATHY" LOGIntroduction

The BATHY log, as provided herein, should be used for recording temperature observations versus depth taken with instruments which provide the temperature with a resolution of 1/10 of degree Celsius or less, such as mechanical or expendable bathythermographs, thermistor chains or others. The TESAC log should be used for temperature values with a higher resolution and/or when salinity or current versus depth are reported (see Annex II). In addition to the temperature information the BATHY log makes provision for encoding sea surface current measurements and depth to the bottom as well as other environmental information. The BATHY log is composed of four parts:

- Part I - Cruise information:
Includes the information concerning the cruise and the country or institution sponsoring the cruise. This information is necessary only once for a cruise.
- Part II - Radio message information:
Contains all information to be transmitted.
- Part III - Station and reference information:
Consists of the information needed to identify a given station and makes provision for entering reference measurements for checking or calibrating the instrument.
- Part IV - Environmental information (optional):
Provides additional information which is helpful for further processing of the data.

Part II is designed according to the reporting code FM 63-VI BATHY published in the Manual on Codes, Volume I (WMO-No. 306) and is for the transmission as a BATHY report. Parts I, III and IV contain the necessary information for the further processing of the BATHY data within the framework of IODE. Therefore, these parts, accompanied by the original trace, should be forwarded to the national agency which delivers the IGOSS data to the IODE system. The complete BATHY log (Figure A) may be modified to meet national requirements. The grid in Part III (Figure A) is used to plot the encoded information taken from Part II. This allows a visual comparison with the original trace and is intended to serve as quality control. An example of a completed log form is given in Figure B.

Coding instructions

Part I - Cruise information (The cruise information is only needed once for a given cruise)

TYPE	<p>Enter the type of platform according to the following table:</p> <table border="1"> <thead> <tr> <th>Code</th> <th>Type</th> <th>Code</th> <th>Type</th> </tr> </thead> <tbody> <tr> <td>1</td> <td>Ship</td> <td>6</td> <td>Aircraft</td> </tr> <tr> <td>2</td> <td>Lightship</td> <td>7</td> <td>Ice island</td> </tr> <tr> <td>3</td> <td>Buoy</td> <td>8</td> <td>Coastal station</td> </tr> <tr> <td>4</td> <td>Fixed tower</td> <td>9</td> <td>Other</td> </tr> <tr> <td>5</td> <td>Submersible</td> <td></td> <td></td> </tr> </tbody> </table>	Code	Type	Code	Type	1	Ship	6	Aircraft	2	Lightship	7	Ice island	3	Buoy	8	Coastal station	4	Fixed tower	9	Other	5	Submersible		
Code	Type	Code	Type																						
1	Ship	6	Aircraft																						
2	Lightship	7	Ice island																						
3	Buoy	8	Coastal station																						
4	Fixed tower	9	Other																						
5	Submersible																								
SHIP'S NAME	Enter the full name of the platform																								
CALL SIGN	Enter the ship call sign where applicable																								
INSTITUTION	Enter the full name of the institution sponsoring or operating the platform during the particular survey																								
COUNTRY	The country's name entered should reflect the nationality of the institution sponsoring or operating the platform during the particular survey																								
PROJECT	When applicable, enter the name of the project, expedition or experiment																								
CRUISE NO.	When applicable, enter the cruise number defined by the appropriate national institution																								

Part II - Radio message information

MESSAGE IDENTIFIER	All BATHY reports must contain the four-character identifier JJXX to distinguish them from other oceanographic/meteorological radio messages. Each subsequent individual BATHY report (i.e. each coded temperature-depth trace) shall begin with the JJXX identifier																																		
DATE	DAY (YY)	Enter the day of the month in GMT by using numerals 01 to 31																																	
	MONTH (MM)	Enter the month of the year in GMT by using numerals 01 to 12																																	
	YEAR (J)	Enter the last digit of the year in GMT																																	
TIME	HOUR (GG)	Enter the time of observation in GMT in hours and minutes. Include the solidus (/) at the end as part of the transmitted group (Morse code for solidus — . . — . (dash, dot, dot, dash, dot))																																	
	MIN (gg)																																		
LATITUDE	QUAD (Qc)	<p>Enter the quadrant of the globe according to the following table:</p> <table border="1" style="display: inline-table; vertical-align: middle;"> <tr> <td></td> <td>N</td> <td></td> </tr> <tr> <td>7</td> <td> </td> <td>1</td> </tr> <tr> <td colspan="3" style="text-align: center;">—</td> </tr> <tr> <td>5</td> <td> </td> <td>3</td> </tr> <tr> <td colspan="3" style="text-align: center;">—</td> </tr> <tr> <td></td> <td>S</td> <td></td> </tr> </table> <table border="1" style="display: inline-table; vertical-align: middle; margin-left: 20px;"> <thead> <tr> <th>Code Figure</th> <th>Latitude</th> <th>Longitude</th> </tr> </thead> <tbody> <tr> <td>1</td> <td>North</td> <td>East</td> </tr> <tr> <td>3</td> <td>South</td> <td>East</td> </tr> <tr> <td>5</td> <td>South</td> <td>West</td> </tr> <tr> <td>7</td> <td>North</td> <td>West</td> </tr> </tbody> </table>		N		7		1	—			5		3	—				S		Code Figure	Latitude	Longitude	1	North	East	3	South	East	5	South	West	7	North	West
	N																																		
7		1																																	
—																																			
5		3																																	
—																																			
	S																																		
Code Figure	Latitude	Longitude																																	
1	North	East																																	
3	South	East																																	
5	South	West																																	
7	North	West																																	
	DEG (L _a L _a)	Enter latitude of the observation in degrees and minutes																																	
	MIN (L _a L _a)																																		
LONGITUDE	DEG (L _o L _o L _o)	Enter longitude of the observation in degrees and minutes																																	
	MIN (L _o L _o)																																		

Part II - Radio message information (contd.)

*WIND	(i _u)	<p><u>Wind speed units indicator</u> - Enter the code figure according to the following table:</p> <table border="1" data-bbox="534 425 1466 731"> <thead> <tr> <th data-bbox="534 425 662 513">Code figure</th> <th data-bbox="662 425 981 513">Units used</th> <th data-bbox="981 425 1466 513">Instruments certified or otherwise</th> </tr> </thead> <tbody> <tr> <td data-bbox="534 513 662 578">0</td> <td data-bbox="662 513 981 578">Metres per second</td> <td data-bbox="981 513 1466 578" rowspan="2">Land stations and ships with certified instruments</td> </tr> <tr> <td data-bbox="534 578 662 644">1</td> <td data-bbox="662 578 981 644">Knots</td> </tr> <tr> <td data-bbox="534 644 662 709">2</td> <td data-bbox="662 644 981 709">Metres per second</td> <td data-bbox="981 644 1466 709" rowspan="2">Ships with uncertified instruments</td> </tr> <tr> <td data-bbox="534 709 662 731">3</td> <td data-bbox="662 709 981 731">Knots</td> </tr> </tbody> </table>	Code figure	Units used	Instruments certified or otherwise	0	Metres per second	Land stations and ships with certified instruments	1	Knots	2	Metres per second	Ships with uncertified instruments	3	Knots
	Code figure	Units used	Instruments certified or otherwise												
	0	Metres per second	Land stations and ships with certified instruments												
1	Knots														
2	Metres per second	Ships with uncertified instruments													
3	Knots														
DIR (dd)	<p><u>True wind direction</u> - Enter the true wind direction, in tens of degrees, from which the wind is blowing. Enter "00" for calm and "36" for a wind direction of 355 degrees to 4 degrees</p>														
SPEED (ff)	<p><u>True wind speed</u> - Enter true wind speed in metres per second or knots. Prefix zeros to fill the field. Enter "00" for calm</p>														
* AIR TEMPERATURE DRY	IN	Indicator for the air temperature group, enter 4													
	± (s _n)	<p><u>Air temperature sign indicator</u> - Enter "0" for temperature positive or zero and "1" for temperature negative</p>													
TEMP DRY (TTT)		<p><u>Air temperature</u> - Enter the air temperature to tenths of a degree Celsius. Prefix zeros to fill the field</p>													
INDICATOR GROUP	(k ₁)	<p>Enter 8888k₁ before recording depth-temperature values at "significant" or "selected depths"</p> <p>Indicator for digitization</p> <p>Enter k₁ = 8 For values at significant depths (data points taken from traces at significant depths)</p> <p>or k₁ = 7 For values at selected depths (data points fixed by the instrument or selected by any other method)</p>													

* Note: The transmission of WIND and AIR TEMPERATURE DRY information are optional

Part II - radioc message information (contd.)

DEPTH	(Z ₀ Z ₀)	Always include temperature at the sea surface (or use the first readable temperature in the upper ten metres for this purpose) Prefix zeros to fill the field
TEMP	(T ₀ T ₀ T ₀)	
DEPTH	(Z _n Z _n)	Enter depth and temperature (tenth of a degree Celsius) at "significant" or "selected" points (see also definition for "significant" or "selected" depth)
TEMP	(T _n T _n T _n)	

The following procedures should be used when encoding the depth-temperature measurements:

- (a) The temperature to be encoded should be taken to the nearest tenth of a degree Celsius. The depth is to be taken to whole metres. Prefix zeros to fill the field;
- (b) In case of a continuous recording it is recommended that "significant" depths be reported ($k_1 = 8$):
 - (i) Select sufficient "significant" depths to describe the basic features of the temperature profile;
 - (ii) Include the depth and temperature of the top and bottom of isothermal layers;
 - (iii) Significant depths shall not exceed 20 in number for the upper 500 metres of the temperature profile even at the cost of loss of detail;
- (c) Do not adjust the trace to agree with the reference temperature or interpret the trace at convenient depth increments (5 m, 20 m, etc.) unless flexure points actually exist at these depths;
- (d) If the instrument used strikes the sea bottom enter five zeros (00000) after the last depth-temperature entry;
- (e) Use $k_1 = 7$ for temperature values taken from ocean data buoys and other instruments yielding fixed depth values;
- (f) To indicate a negative temperature add 50.0 to the absolute value of the temperature and drop the negative sign;

(g) As there are only two digits to indicate the depth, each increase in 100 m interval has to be indicated. Therefore, the code 999zz has to precede the first depth-temperature value in each 100 m interval containing a significant or selected depth. zz is coded as follows:

- 99901 for the interval 100 to 199 metres
- 99902 for the interval 200 to 299 metres
- .
- .
- .
- 99910 for the interval 1000 to 1099 metres
- 99911 for the interval 1100 to 1199 metres
- .
- .
- .
- 99920 for the interval 2000 to 2099 metres

The tens and units digits of depths are then entered with the corresponding temperatures. For example:

	<u>zzTTT</u>	<u>zzTTT</u>	<u>zzTTT</u>
	99901	50128	75053
The following values at	100 metres	150 metres 12.8° Celsius	175 metres 5.3° Celsius

(h) The temperature at the lowest depth of the sounding shall be reported in the last temperature group.

INDICATOR GROUP	Insert 66666 if the "TOTAL WATER DEPTH " and/or the "SEA SURFACE CURRENT" are included in the BATHY report
*TOTAL WATER DEPTH IN (z _d z _d z _d z _d)	Enter 1 indicator for the TOTAL WATER DEPTH group Enter the sounding depth to the nearest metre for the station Note: Group (1z _d z _d z _d z _d) shall be omitted when group 00000 (instrument hits the bottom) is used

*Note: The transmission of TOTAL WATER DEPTH is optional

Part II - Radio message information (contd.)

<p>*SS-CURRENT (Sea surface current)</p> <p>DIR (D_cD_c)</p> <p>SPEED (V_cV_c)</p>	<p>k₅ Indicator for measuring method: Enter k₅= 2: GEK (Geomagnetic Electrokinetograph) k₅= 3: Ship's set and drift determined by fixes 3-6 hours apart k₅= 4: Ship's set and drift determined by fixes, more than 6 hours but less than 12 hours, apart</p> <p>Surface current direction: Enter direction in tens of degrees towards which sea current is moving</p> <p>Enter surface current speed in 0.1 knots</p>
<p>SHIP CALL SIGN</p>	<p>Enter call sign or letter "SHIP"</p> <p>Note: The radio call sign which also acts as a radio message terminator should terminate each report</p>

Part III - Station and reference information

<p>STATION NO.</p>	<p>When applicable enter the station number of other designator assigned by cruise plan or local location grid</p>
<p>DEPTH TO BOTTOM</p>	<p>Enter the sounding depth to the nearest metre for the station</p>

* Note: Transmission of SEA SURFACE CURRENT is optional

Part III - Station and reference information (contd.)

LATITUDE	DEG MIN Q _c	Enter latitude (degrees and minutes) as accurately as the method for navigation permits Quadrant of the globe according to Q _c in Part II or according to national practice (e.g. N/S/E/W)
LONGITUDE	DEG MIN Q _c	(see above)
DATE	YEAR MONTH DAY	Enter the year, month and day in GMT
TIME	HOUR MIN	Enter the hour and minutes in GMT
INSTRUMENT	TYPE NUMBER LETTER	Enter type of instrument used (e.g. XBT) and serial number
REFERENCE MEASUREMENT	DEPTH TEMP	Each observation should be accompanied by an independent reference measurement in order to monitor the function of the instrument Enter depth from sea surface at which the reference measurement is taken Enter temperature value of the reference measurement as accurately as the method allows

Part III - Station and reference information (contd.)

REFERENCE MEASUREMENT (contd.)	<p>Enter code for the method of obtaining reference measurement:</p> <p>1 Bucket thermometer</p> <p>2 Thermometer inlet of engine cooling system on motor ships</p> <p>3 Trailing thermistor</p> <p>4 Hull contact sensor</p> <p>5 "Through hull" sensor</p> <p>6 Radiation thermometer</p> <p>7 Bait tank thermometer</p> <p>9 Others</p> <p>Note: If "9" is entered describe the instrument</p>
--------------------------------------	---

Part IV - Environmental information

WIND	DIR	Enter true wind direction, in degrees, from which the wind is blowing
	SPEED	Enter true wind speed in metres per second or in knots
	HEIGHT OF OBSERVATION	Enter height in metres above sea level at which wind measurement is taken
	METHOD	Enter method of wind measurement in plain language (e.g. anemometer, estimated)
AIR TEMP	TEMP DRY	Enter air temperature DRY to tenths of a degree Celsius
	TEMP WET	Enter air temperature WET to tenths of a degree Celsius
	HEIGHT OF OBS	Enter height in metres above sea level at which temperature measurement is taken

Part IV - Environmental information (contd.)

PRESSURE		Enter the corrected sea level barometric pressure to tenths of a millibar
PRECIPITATION		Enter the amount of precipitation for six hours preceding the time of observation to the nearest 0.2 mm
SOLAR RAD.		Enter the value of radiation and indicate the method of observation
SWELL	DIR	Enter direction from which the swell is coming in degrees
	PERIOD	Enter the period of swell in seconds
	HEIGHT	Enter the height of swell (crest to trough) to the nearest half metre
	METHOD	Enter the method used to determine the swell (e.g. measured, estimated)
WIND WAVES	PERIOD	Enter wind wave period to the nearest second
	HEIGHT	Enter wave height (crest to trough) to the nearest half metre
	METHOD	Enter method used to determine the wind sea

BATHY

PART I CRUISE INFORMATION

TYPE	SHIP'S NAME	CALL SIGN	INSTITUTION
COUNTRY		PROJECT	CRUISE NO

PART II RADIO MESSAGE INFORMATION

MESSAGE IDENTIFIER	DATE (GMT)	TIME (GMT)	LATITUDE	LONGITUDE	WIND			AIR TEMP			INDICATOR GROUP					
	DAY MONTH YR	HOUR MIN			DIR	SPEED	I	±	TEMP	dry						
	Y Y M M J	G G g g			Qc	Lo La La La	Lo Lo Lo Lo Lo	'u	d	d		l	l	N	s	n

OPTIONAL

J	J	X	8	8	8	8	4
---	---	---	---	---	---	---	---

DEPTH	TEMP	DEPTH	TEMP	DEPTH	TEMP	DEPTH	TEMP	DEPTH	TEMP	DEPTH	TEMP	DEPTH	TEMP	DEPTH	TEMP	DEPTH	TEMP	DEPTH	TEMP																		
Zo	Zo	To	To	To	Z	Z	T	T	T	Z	Z	T	T	T	Z	Z	T	T	T	Z	Z	T	T	T	Z	Z	T	T	T	Z	Z	T	T	T			
0	0																																				

INDICATOR GROUP	TOTAL WATER - DEPTH	SS-CURRENT	CALL SIGN
I	N	z _d z _d z _d z _d	k s Dc Dc Vc Vc
6	6	6	6
1			

PART III STATION and REFERENCE INFORMATION

STATION NO.	DEPTH TO BOTTOM
LATITUDE	LONGITUDE
DEG MIN Qc	DEG MIN Qc
DATE	TIME
YEAR MONTH DAY	HOUR MIN
INSTRUMENT	
TYPE	NUMBER and LETTER
REFERENZ MEASUREMENTS	
DEPTH	TEMP
	METHOD

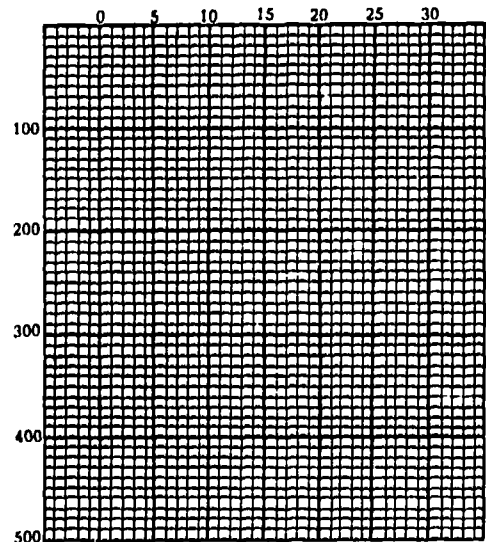

PART IV ENVIRONMENTAL INFORMATION

WIND			METHOD		
DIR	SPEED	HEIGHT of OBS			
AIR TEMP			PRESSURE	PRECIPITATION	SOLAR RAD.
TEMP dry	TEMP wet	HEIGHT of OBS			
SWELL			WIND WAVES		
DIR	PERIOD	HEIGHT	METHOD	PERIOD	HEIGHT

Fig. B

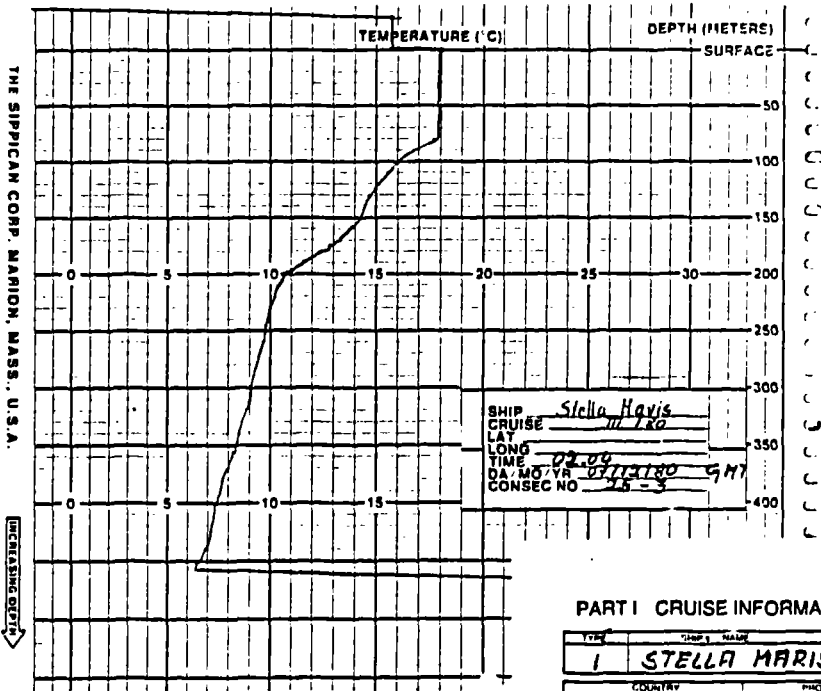

E X A M P L E
Coded BATHY message

PART I CRUISE INFORMATION

SHIP NAME	CALL SIGN	INSTITUTION
1 STELLA MARIS TGIF		Just. of Ocean Research
COUNTRY	PROJECT	CRUISE NO.
Rep. of Honduras	WCRT	III 180

BATHY

PART II RADIO MESSAGE INFORMATION

MESSAGE IDENTIFIER	DATE (GMT)		TIME (GMT)		LATITUDE		LONGITUDE		WIND		AIR TEMP		INDICATOR GROUP				
	DAY	MONTH	HR	MIN	DEG	MIN	DEG	MIN	DIR	DIR	DIR	DIR					
JJXX	07	12	02	04	13	53	139	44	01	10	40	24	88888				
DEPTH TEMP	DEPTH	TEMP	DEPTH	TEMP	DEPTH	TEMP	DEPTH	TEMP	DEPTH	TEMP	DEPTH	TEMP	DEPTH	TEMP			
00	180	78	180	99	90	00	160	50	143	80	125	99	902	00	180	50	098
99	903	00	09	50	08	4	99	90	4	00	07	5	50	06	7		
INDICATOR GROUP	TOTAL WIND DEPTH		NO. OF SURFAC		NO. OF SURFAC		NO. OF SURFAC		NO. OF SURFAC		NO. OF SURFAC		CALL SIGN				
66666	14520												TGIF				

PART III STATION and REFERENCE INFORMATION

STATION NO.	DEPTH TO REFLECT	
# 25-3	4528	
LATITUDE	LONGITUDE	
35 30.6 N	139 44.3 W	
DATE	TIME	
1980 Dec 7	02 04	
TYPE	NUMBER AND LETTER	
XBT	MK3 / 716128	
DEPTH	TEMP	METHOD
0	18.1	bucket

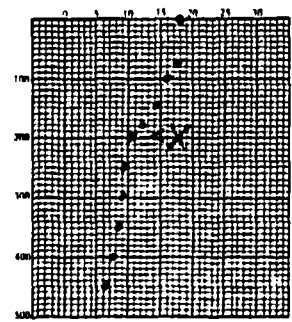

PART IV ENVIRONMENTAL INFORMATION

DIR	SPEED	HEIGHT	WIND	SH (FEET)	
113	6 m/sec	18 m	anemometer		
TEMP	TEMP	TEMP	PRESSURE	PRECIPITATION	SILAR RAD
24.2	23.8	18 m	1028 mb		
DIR	PERIOD	DEPTH	WIND	SWELL	SH (FEET)
210°	8 sec	1.0 m	estim.		
PERIOD	DEPTH	WIND	SWELL	SH (FEET)	
0.5 sec	0.5 m	estim.			

INSTRUCTIONS FOR PREPARING THE "TESAC" LOGIntroduction

The TESAC log, as provided herein, should be used if one or all of the following data sets are available:

- Temperature versus depth with a resolution of 1/100 of a degree Celsius
- Temperature and salinity versus depth
- Current versus depth.

The TESAC log is composed of four parts:

Part I - Cruise information

Includes the information concerning the cruise and the country or institution sponsoring the cruise. This information is necessary only once for a cruise.

Part II - Radio message information

Contains all information to be transmitted.

Part III - Station and reference information

Consists of the information needed to identify a given station and makes provision for entering reference measurements for checking or calibrating the instrument.

Part IV - Environmental information (optional)

Provides additional information which is helpful for further processing of the data.

Part II is designed according to the reporting code FM 64-VI TESAC published in the Manual on Codes, Volume I (WMO-No. 306) and is for transmission as a TESAC report. Parts I, III and IV contain the necessary information for further processing of the TESAC data within the framework of IODE. Therefore, these parts accompanied by the original data should be forwarded to the national agency which delivers the IGOSS data to the IODE system. The complete TESAC log (Figure C) may be modified to meet national requirements. The grid in Part III (Figure C) is used to plot the encoded information taken from Part II. This allows a visual comparison with the original trace and is intended to serve as quality control. An example of a completed log form is given in Figure D.

Coding instructions

Part I - Cruise information (The cruise information is only needed once for a given cruise)

TYPE	<p>Enter the type of platform according to the following table:</p> <table border="1"> <thead> <tr> <th>Code</th> <th>Type</th> <th>Code</th> <th>Type</th> </tr> </thead> <tbody> <tr> <td>1</td> <td>Ship</td> <td>6</td> <td>Aircraft</td> </tr> <tr> <td>2</td> <td>Lightship</td> <td>7</td> <td>Ice island</td> </tr> <tr> <td>3</td> <td>Buoy</td> <td>8</td> <td>Coastal station</td> </tr> <tr> <td>4</td> <td>Fixed tower</td> <td>9</td> <td>Other</td> </tr> <tr> <td>5</td> <td>Submersible</td> <td></td> <td></td> </tr> </tbody> </table>	Code	Type	Code	Type	1	Ship	6	Aircraft	2	Lightship	7	Ice island	3	Buoy	8	Coastal station	4	Fixed tower	9	Other	5	Submersible		
Code	Type	Code	Type																						
1	Ship	6	Aircraft																						
2	Lightship	7	Ice island																						
3	Buoy	8	Coastal station																						
4	Fixed tower	9	Other																						
5	Submersible																								
SHIP'S NAME	Enter the full name of the platform																								
CALL SIGN	Enter the ship call sign where applicable																								
INSTITUTION	Enter the full name of the institution sponsoring or operating the platform during the particular survey																								
COUNTRY	The country's name entered should reflect the nationality of the institution sponsoring or operating the platform during the particular survey																								
PROJECT	When applicable, enter the name of the project, expedition or experiment																								
CRUISE NO.	When applicable, enter the cruise number defined by the appropriate national institution																								

Part II - Radio message information

MESSAGE IDENTIFIER		All TESAC reports must contain the four-character identifier KKXX to distinguish them from other oceanographic/meteorological radio messages. Each subsequent individual TESAC report (i.e. each coded temperature-salinity-current-depth trace) shall begin with the KKXX identifier																																		
DATE	DAY (YY)	Enter the day of the month in GMT by using numerals 01 to 31																																		
	MONTH (MM)	Enter the month of the year in GMT by using numerals 01 to 12																																		
	YEAR (J)	Enter the last digit of the year in GMT																																		
TIME	HOUR (GG)	Enter the time of observation in GMT in hours and minutes. Include the solidus (/) at the end as part of the transmitted group (Morse code for solidus — . . — . (dash, dot, dot, dash, dot))																																		
	MIN (gg)																																			
LATITUDE	QUAD (Qc)	Enter the quadrant of the globe according to the following table:																																		
		<table border="1"> <tr> <td></td> <td>N</td> <td></td> <td></td> </tr> <tr> <td>7</td> <td> </td> <td>1</td> <td></td> </tr> <tr> <td>W</td> <td>—</td> <td>—</td> <td>E</td> </tr> <tr> <td>5</td> <td> </td> <td>3</td> <td></td> </tr> <tr> <td></td> <td>S</td> <td></td> <td></td> </tr> </table> <table border="1"> <thead> <tr> <th>Code Figure</th> <th>Latitude</th> <th>Longitude</th> </tr> </thead> <tbody> <tr> <td>1</td> <td>North</td> <td>East</td> </tr> <tr> <td>3</td> <td>South</td> <td>East</td> </tr> <tr> <td>5</td> <td>South</td> <td>West</td> </tr> <tr> <td>7</td> <td>North</td> <td>West</td> </tr> </tbody> </table>		N			7		1		W	—	—	E	5		3			S			Code Figure	Latitude	Longitude	1	North	East	3	South	East	5	South	West	7	North
	N																																			
7		1																																		
W	—	—	E																																	
5		3																																		
	S																																			
Code Figure	Latitude	Longitude																																		
1	North	East																																		
3	South	East																																		
5	South	West																																		
7	North	West																																		
	DEG (L _a L _a)	Enter latitude of the observation in degrees and minutes																																		
	MIN (L _a L _a)																																			
LONGITUDE	DEG (L _o L _o L _o)	Enter longitude of the observation in degrees and minutes																																		
	MIN (L _o L _o)																																			

Part II - Radio message information (contd.)

<p>* WIND</p> <p>(i_u)</p> <p>DIR (dd)</p> <p>SPEED (ff)</p>	<p><u>Wind speed units indicator</u> - Enter the code figure according to the following table:</p> <table border="1"> <thead> <tr> <th>Code figure</th> <th>Units used</th> <th>Instruments certified or otherwise</th> </tr> </thead> <tbody> <tr> <td>0</td> <td>Metres per second</td> <td rowspan="2">Land stations and ships with certified instruments</td> </tr> <tr> <td>1</td> <td>Knots</td> </tr> <tr> <td>2</td> <td>Metres per second</td> <td rowspan="2">Ships with uncertified instruments</td> </tr> <tr> <td>3</td> <td>Knots</td> </tr> </tbody> </table> <p><u>True wind direction</u> - Enter the true wind direction, in tens of degrees, from which the wind is blowing. Enter "00" for calm and "36" for a wind direction of 355 degrees to 4 degrees</p> <p><u>True wind speed</u> - Enter true wind speed in metres per second or knots. Prefix zeros to fill the field. Enter "00" for calm</p>	Code figure	Units used	Instruments certified or otherwise	0	Metres per second	Land stations and ships with certified instruments	1	Knots	2	Metres per second	Ships with uncertified instruments	3	Knots
Code figure	Units used	Instruments certified or otherwise												
0	Metres per second	Land stations and ships with certified instruments												
1	Knots													
2	Metres per second	Ships with uncertified instruments												
3	Knots													
<p>* AIR TEMPERATURE DRY</p> <p>IN</p> <p>± (s_n)</p> <p>TEMP DRY (TTT)</p>	<p>Indicator for the air temperature group, enter 4</p> <p><u>Air temperature sign indicator</u> - Enter "0" for temperature positive or zero and "1" for temperature negative</p> <p><u>Air temperature</u> - Enter the air temperature to tenths of a degree Celsius. Prefix zeros to fill the field</p>													
<p>INDICATOR GROUP</p> <p>(k₁)</p>	<p>Enter 888k₁k₂ before recording depth-temperature values at "significant" or "selected depths"</p> <p>Indicator for digitization</p> <p>Enter k₁ = 8 for values at significant depths (data points taken from traces at significant depths)</p> <p>or k₁ = 7 For values at selected depths (data points fixed by the instrument of selected by any other method)</p>													

* Note: The transmission of WIND and AIR TEMPERATURE information are optional

Part II - Radio message information (contd.)

INDICATOR GROUP (contd.)	(k ₂)	Method of salinity/depth measurement Enter k ₂ = 0 No salinity measured (Omit the salinity groups) k ₂ = 1 In situ sensor, accuracy better than 0.02 o/oo k ₂ = 2 In situ sensor, accuracy less than 0.02 o/oo k ₂ = 3 Sample analysis
DEPTH	IN (Z _o Z _o Z _o Z _o)	Indicator for depth. Enter 2 Enter depth to the nearest metre of the uppermost measurement
TEMP	IN (T _o T _o T _o T _o)	Indicator for temperature. Enter 3 Enter temperature in hundredth of a degree Celsius of the uppermost measurement
SAL	IN (S _o S _o S _o S _o)	Indicator for salinity. Enter 4 Enter salinity in hundredth of the salinity unit of the uppermost measurement
DEPTH	IN (ZZZZ)	Enter depth, temperature and salinity at "significant" or "selected" points In case salinity or temperature is not measured, omit the corresponding group
TEMP	IN (TTTT)	
SAL	IN (SSSS)	

The following procedures should be used when encoding the depth-temperature-salinity measurement:

- (a) The temperature to be encoded should be taken to the nearest hundredth of a degree Celsius. The salinity to be encoded should be taken to the nearest hundredth of the salinity unit. The depth is to be taken to whole metres. Prefix zeros to fill the field;

- (b) In case of a continuous recording it is recommended that "significant" depths be reported ($k_1=8$):
- (i) Select sufficient "significant" depths to describe the basic features of the temperature and salinity profiles;
 - (ii) Include the depth, temperature and salinity of the top and bottom of isothermal and isohaline layers;
 - (iii) Significant depths shall not exceed 20 in number for the upper 500 metres of the temperature/salinity profile even at the cost of loss of detail;
- (c) Do not adjust the trace to agree with the reference temperature/salinity or interpret the trace at convenient depth increments (5 m, 20 m, etc.) unless flexure points actually exist at these depths;
- (d) If the instrument used strikes the sea bottom enter five zeros (00000) after the last depth-temperature-salinity entry;
- (e) Use $k_1=7$ for temperature/salinity values taken from ocean data buoys¹ and other instruments yielding fixed depth values;
- (f) To indicate a negative temperature add 50.0 to the absolute value of the temperature and drop the negative sign;
- (g) The temperature/salinity at the lowest depth of the sounding shall be reported in the last temperature/salinity group. If only temperature is taken at the sea surface, it should be reported in the first group.

* CURRENT INDICATOR GROUP	(k_3)	Insert 666 k_3k_4 if sea surface current or current versus depth are included in the TESAC report
	(k_4)	Duration and time of current measurement according to Table 2264 of Manual on Codes (WMO-No. 306) Period of current measurement (drift method) according to Table 2265 of Manual on Codes (WMO-No. 306)
DEPTH	IN $(Z_o Z_o Z_o Z_o)$	Indicator for depth. Enter 2 Enter depth to the nearest meter of the uppermost measurement
DIR	$(d_o d_o)$	Enter the direction in tens of degrees towards which the current of the uppermost measurement is moving

* Note: The transmission of current data is optional

Part II - Radio message information (contd.)

SPEED	(C _o C _o C _o)	Enter the speed of the current of the uppermost measurement
DEPTH	IN (ZZZZ)	Enter the depth, direction and speed of the current at the selected depth
DIR	(dd)	
SPEED	(CCC)	
INDICATOR GROUP		Insert 55555 if the "TOTAL WATER DEPTH" is included in the TESAC report
* TOTAL WATER DEPTH	IN (Z _d Z _d Z _d Z _d)	Indicator for the total water depth group. Enter 1 Enter the sounding depth to the nearest metre for the station
SHIP CALL SIGN		Enter the ship call sign of the letters "SHIP" Note: The ship radio call sign, which also acts as a radio message terminator, should terminate each report

Part III - Station and reference information

STATION NO.		When applicable enter the station number or other designator assigned by cruise plan or local location grid
DEPTH TO BOTTOM		Enter the sounding depth to the nearest metre for the station
LATITUDE	DEG MIN Q _c	Enter the latitude (degrees and minutes) as accurately as the method for navigation permits Quadrant of the globe according to Q _c in Part II or according to national practices (e.g. N/S/E/W)

* Note: Transmission of TOTAL WATER DEPTH is optional

Part III - Station and reference information (contd.)

LONGITUDE	DEG MIN Q _c	Enter the latitude (degrees and minutes) as accurately as the method for navigation permits Quadrant of the globe according to Q _c in Part II or according to national practices (e.g. N/S/E/W)
DATE	YEAR MONTH DAY	Enter the year, month and day in GMT
TIME	HOUR MIN	Enter the hour and minutes in GMT
INSTRUMENT	TYPE NUMBER LETTER	Enter type of instrument used (e.g. STD) and serial number
REFERENCE MEASUREMENT	DEPTH VALUE METHOD	Each observation should be accompanied by an independent reference measurement in order to monitor the function of the instrument Enter the depths from sea surface at which the reference measurements are taken Enter the temperature or salinity value of the reference measurement as accurately as the method allows Enter the methods used for obtaining reference measurements in plain language

Part IV - Environmental information

WIND	DIR SPEED	Enter the true wind direction from which the wind is blowing in degrees Enter true wind speed in metres per second or in knots
------	------------------	---

Part IV - Environmental information (contd.)

WIND (contd.) HEIGHT OF OBSERVATION METHOD	Enter the height in metres above sea level at which the wind measurement is taken Enter the method of the wind measurement in plain language (e.g. anemometer, estimated)
AIR TEMP TEMP DRY TEMP WET HEIGHT OF OBS	Enter the air temperature DRY to tenths of a degree Celsius Enter the air temperature WET to tenths of a degree Celsius Enter the height in metres above sea level at which the temperature measurement is taken
PRESSURE	Enter the corrected sea level barometric pressure to tenths of a millibar
PRECIPITATION	Enter the amount of precipitation for the six hours preceding the time of observation to the nearest 0.2 mm
SOLAR RAD.	Enter the value of radiation and indicate the method of observation
SWELL DIR PERIOD HEIGHT METHOD	Enter the direction from which the swell is coming in degrees Enter the period of swell in seconds Enter the height of swell (crest to trough) to the nearest half metre Enter the method used to determine the swell (e.g. measured, estimated)
WIND WAVES PERIOD HEIGHT METHOD	Enter the wind wave period to the nearest second Enter the wave height (crest to trough) to the nearest half metre Enter the method used to determine the wind sea

TESAC

PART I CRUISE INFORMATION

TYPE	SHIP'S NAME	CALL SIGN	INSTITUTION
COUNTRY		PROJECT	CRUISE NO

PART II RADIO MESSAGE INFORMATION

MESSAGE IDENTIFIER K K X X	DATE (GMT)			TIME (GMT)			LATITUDE Qc La La La La	LONGITUDE Lo Lo Lo Lo Lo				WIND DIR SPEED			AIR TEMP I ± TEMP dry		INDICATOR GROUP k1 k2					
	DAY	MONTH	YR	HOUR	MIN			DEG	MIN		DEG	MIN		DIR	SPEED	I	±	TEMP	dry	GROUP	k1	k2
	Y	M	J	G	g	g		Qc	La	La	La	La	Lo	Lo	Lo	Lo	I		N	sn	T	T

DEPTH	TEMP	SAL	DEPTH	TEMP	SAL	DEPTH	TEMP	SAL
N Z0 Z0 Z0 Z0	N T0 T0 T0 T0	N S0 S0 S0 S0	N Z Z Z Z	N T T T T	N S S S S	N Z Z Z Z	N T T T T	N S S S S
2	3	4	2	3	4	2	3	4

INDICATOR GROUP	DEPTH	DIR SPEED	DEPTH	DIR SPEED	DEPTH	DIR SPEED	DEPTH	DIR SPEED
N Z0 Z0 Z0 Z0	N Z Z Z Z	d d c c c c	N Z Z Z Z	d d c c c c	N Z Z Z Z	d d c c c c	N Z Z Z Z	d d c c c c
6 6 6	2		2		2		2	

INDICATOR GROUP	TOTAL WATER - DEPTH	CALL SIGN
N Zd Zd Zd Zd	I	
5 5 5 5 5	1	

PART III STATION and REFERENCE INFORMATION

STATION NO.			DEPTH TO BOTTOM		
LATITUDE			LONGITUDE		
DEGR	MIN	Qc	DEG	MIN	Qc
DATE			TIME		
YEAR	MONTH	DAY	HOUR	MIN	
INSTRUMENT					
TYPE		NUMBER and LETTER			
REFERENZ MEASUREMENTS					
DEPTH	VALUE	METHOD			
TEMP					
SAL					

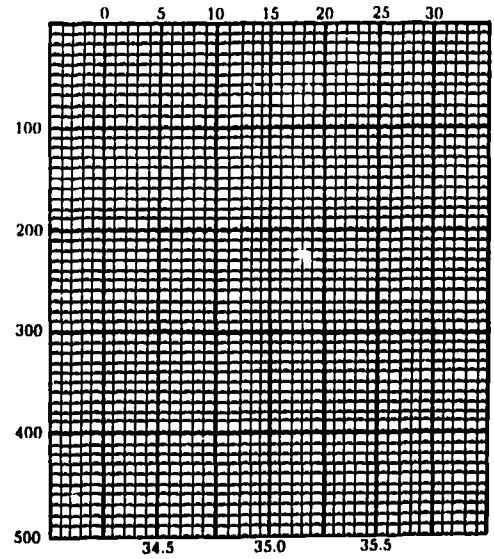

PART IV ENVIRONMENTAL INFORMATION

WIND			
DIR	SPEED	HEIGHT of OBS	METHOD

AIR TEMP			PRESSURE	PRECIPITATION	SOLAR RAD.
TEMP dry	TEMP wet	HEIGHT of OBS			

SWELL				WIND WAVES		
DIR	PERIOD	HEIGHT	METHOD	PERIOD	HEIGHT	METHOD

Simplified lay-out of a BATHY or TESAC message
exchanged over the GTS

Starting line: ZCZC nnn CL₁L₂L₃L₄

- ② ZCZC (symbol) = Start of heading
- ② nnn (number) = Transmission sequence number (000 to 999)
- ② CL₁L₂L₃L₄ (figures) = Group for classification and identification of bulletins
 - C and L₃ identify the types of data contained in the bulletin
(for BATHY or TESAC reports from ships, C = 1, L₃ = 7)
 - L₁L₂ and L₄ identify the bulletin originating centre and the individual bulletin

Abbreviated heading: TTA₁A₂ii CCCC YYGGgg (BBB)

- ② TT (letters) : Data designator for alphanumeric information
(for BATHY or TESAC reports: TT = SO)
- ② A₁A₂ (letters): Geographical designator
(for BATHY or TESAC reports: A₁ = W for ocean weather stations
= V for mobile ships and other marine station
A₂ denotes the regions (of WMO) from which the reports originate)
- ② ii (figures) : indicator of the distribution of the bulletin (global, regional, national)
- ② CCCC (letters) : indicator of the station originating or compiling the bulletin
- ② YYGGgg (figures):. international date-time group
 - . YY: day of month
 - . GGgg: hour and minutes in GMT
(for BATHY or TESAC reports, this is the date-time of compiling the bulletin for insertion onto the GTS and does not refer to observations time)
- ② BBB (letters): indicator to be used for an addition or a correction to a previous bulletin defined by GTS abbreviated heading.

Text: A set of REPORTS in one code form only (FM 63-V for BATHY reports or FM 64-V for TESAC reports) separated by the symbol = (see annexes... and...)

End-of-message: NNNN (symbol) = End of text

BULLETIN

MESSAGE

Example of a BATHY message
exchanged over the GTS

[/Note: indicator of the station and ship's call signs are hypothetical]

A message may appear as follows (on a classical print-out):

```
ZCZC      004  14772
SOVD2     LOVE 071943
JJXX      07120 0000/ 73456 12802 88888 00170
33171     39180 51183 89157 99901 04157 20141
28147     60110 80100 99902 19092 65080 99904
50057     GOLF  =
JJXX      07120 0000/ 75348 15841 10535 41075
88888     00054 05054 25061 35058 70058 75042
90039     99901 30039 60040 65039 85040 99902
30040     35039 99904 05039 10038 50038 ZULU =
JJXX      07120 0204/ 73531 13944 01106 40242
88888     00180 78180 99901 00160 50143 80125
99902     00180 50098 99903 00091 50084 99904
00075     50067 66666 15850 32604 TGIF  =
NNNN
```

It must be read as follows:

(1)

Message level

- ZCZC is the symbol for start of heading
- 004 is nnn: Transmission sequence number
- 14772 is CLLLL: group for classification and identification of bulletins
 - . C = 1 means: surface data for global exchange
 - . L₁L₂ = 47 means: bulletin originating center is in WMO Region IV (North and Central America)
 - . L₃ = 7 (in combination with C = 1) means: oceanographic data (BATHY or TESAC)
 - . L₄ = 2 identifies an individual bulletin along a procedure defined by the concerned RTH

(2) Bulletin level

- SOVD2 is TTAAii: data designator, geographical designator, distribution designator
 - . TT = SO means: oceanographic data (BATHY or TESAC)
 - . AA = VD means: reports originated from mobile ships or other marine stations (A₁ = V) except ocean weather stations and from WMO Region IV (A₂ = D)
 - . ii = 2 means: bulletin for global distribution

- LOVE is CCCC: indicator of the GTS centre compiling the bulletin

- 071943 is YYGGgg: international date-time group indicating when the bulletin was compiled, meaning here: the 7th of the month, 19h 43 GMT

(3) Report level

First report

- JJXX is MiMiMjMj: identification group, meaning here: report of bathythermal observation

- 07120 is YYMMJ: day of the month, month of the year, units digit of the year (all GMT), meaning here: 7 December 1980

- 0000/ is GGgg/: observation time GMT (time of launching of the bathythermograph), meaning here: 00h 00 GMT

- 73456 is QcLaLaLaLa: quadrant of the globe, latitude in degrees and minutes, meaning here: Latitude North, Longitude W, 34°56'N

- 12802 is LoLoLoLoLo: longitude in degrees and minutes, meaning here (in combination with Qc = 7) 128°02'W

- 88888 is 8388k₁: a symbolic figure group meaning that data on temperatures versus depths follow. k₁ = 8 means that temperature at significant depths follow.

- 00170 is zozoToToTo: significant depth in metres, temperature in tenths of a degree Celsius at that specified depth, meaning here: 17.0°C at the surface

- 33171 is z₁z₁T₁T₁T₁: - id - 17.1°C at 33 m of depth

- 39180 is z₂z₂T₂T₂T₂: - id - 18.0°C at 39 m of depth

- 51183 is z₃z₃T₃T₃T₃: - id - 18.3°C at 51 m of depth

- 89157 is z₄z₄T₄T₄T₄: - id - 15.7°C at 89 m of depth

- 99901 is 999zz: 999 is a symbolic figure group meaning that data on hundreds of metres of depth (zz) follow; since z₁z₁ indicates depth from 00-99 meters the 999zz is a code flag indicating that the following depths are equal to or greater than zz hundred meters. ie. zz = 01 = all depths following should be read 1z₁z₁ meters; zz = 12 = 12z₁z₁ meters.

- 04157 is z₁z₁T₁T₁T₁: (see above): 15.7°C at 104 m. of depth etc...
The remaining reads: 14.1°C at 120 m.; 14.7°C at 128 m.;
11.0°C at 160 m.; 10.0°C at 180 m.; 9.2°C at 219 m.;
8.0°C at 265 m.; 5.7°C at 450 m.
- GOLF is DDDD, the ship's call sign

(2) Bulletin level

- = is the symbol separating two reports within the bulletin

(3) Reports level

Second report (see above for explanation)

A BATHY observation has been made the 7 December 1980 at 00h 00 GMT, at 53°48'N and 158°41'W

- 10535 is i_uddff (optional group): wind and instrument indicator, true direction in tens of degrees from which wind is blowing, wind speed in units indicated by i_u, meaning here: wind speed measured in knots with certified instruments, blowing from 050° at 35 knots
- 41075 is 4s_nTTT (optional group): symbolic figure meaning that data on air temperature follow, sign of temperature, air temperature in tenths of a degree Celsius, meaning here: air temperature is - 7.5°C

Sea temperatures have been recorded at the following significant depths:

5.4°C at the surface; 5.4°C at 5 m. of depth; 6.1°C at 25 m.; 5.8°C at 35 m.;
5.8°C at 70 m.; 4.2°C at 75 m.; 3.9°C at 90 m.; 3.9°C at 130 m.; 4.0°C at 160 m.;
3.9°C at 165 m.; 4.0°C at 185 m.; 4.0°C at 230 m.; 3.9°C at 235 m.; 3.9°C at 405 m.;
3.8°C at 410 m.; 3.8°C at 450 m. Ship's call sign is ZULU

(2) Bulletin level

- = (see above)

(3) Reports level

Third report (see above for explanation)

A BATHY observation has been made the 7 December 1980 at 02h 04 GMT, at 35°31'N and 139°44'W. The wind was blowing from 110° at 6 meters per second (measured with a certified instrument). The air temperature was +24.2°C. Sea temperatures have been recorded at the following significant depths: 18.0°C at the surface; 18.0°C at 78 m. of depth; 16.0°C at 100 m.; 14.3°C at 150 m.; 12.5°C at 180 m.; 18.0°C at 200 m. (this value is obviously erroneous and comes most likely from an encoding or a transmission error); 9.8°C at 250 m.; 9.1°C at 300 m.; 8.4°C at 350 m.; 7.5°C at 400 m.; 6.7°C at 450 m.

- 66666 (optional group): a symbolic figure group meaning that data on total water depth and/or sea surface current follow.

- 15850 is $1Z_d Z_d Z_d Z_d$: (optional group): symbolic figure meaning that data on total water depth follow, total water depth in meters, here 5850 m.

- 32604 is $k_5 D_c D_c V_c V_c$: (optional group): symbolic figure meaning that data on ship's set and drift determined by fixes 3-6 hours apart follow, direction in tens of degrees towards which sea current is moving, sea current speed in tenths of a knot, meaning here: sea surface current moving towards 260° at .4 knot.

Ship's call sign is TGIF.

(2)

Bulletin level

- (see above)

(1)

Message level

- NNNN is the symbol indicating end of text.

Minimum Quality Control Procedures for
IGOSS Data to be transmitted on the GTS

A. It is recommended that the following minimum quality control procedures be used prior to insertion of IG OSS data onto the GTS. These checks concern essentially the correct formatting of BATHY/ TESAC Bulletins and are intended to be carried out on a computer using interactive editing procedures. However, if the amount of data is low, the procedures can be carried out manually.

1. Check if a set of reports can be separated into individual reports.
2. If there are combined reports (two or more strung together) determine if each report contains:
 - a) the proper prefix, if not, insert JJXX or KKXX.
 - b) a call sign, if not - and call sign is known - insert it.
If not known, insert "SHIP".
 - c) a report separation signal, if not, insert "=" at the end.
3. If there are individual reports, check if the report separation signal "=" appears at the end of every individual report, if not, insert "=".
4. Check if the length of the report is less than 30 characters (numbers, alphanumerics, and blanks). If so, do not transmit.
5. Check if report contains more than three non-5 digit groups exclusive of the JJXX and call sign. If so, do not transmit.
6. Check if the 5th character of the time group is a "/".
 - a) If it is a "9", leave "9" in place / the report is then in degrees Fahrenheit and depth is in feet /.
 - b) If it is a "0", replace by "/".
 - c) If it is a numeral other than "9" or "0", do not change.
 - d) If it is a blank, insert "/".

Note: Formats FM 63-VI and 64-VI do not recognize characters other than the solidus "/" in the 5th place of the time group. In cases where a national practice has been adopted to use this place to indicate a change such as English units, the GTS insertion centre should strive to correct the format for international exchange, i.e. to insert the solidus and assure temperatures are in degrees Celsius and depths in meters.

7. Check if there are characters other than numbers between JJXX/KKXX and call sign, except for "/" in time group, either correct it manually, or delete the group.

Minimum Quality Control Procedures for IGOSS Data taken from the GTS

A. The quality control checks described in this Annex will normally be carried out by computer. Changes to data values should only be made if there is a high degree of confidence that the change is warranted. Following the performance of the quality control operations, the appropriate flags must be attached to all physical values before the data are forwarded to users or to the IODE system for archiving. In this document, the position and time values are considered to be physical variables.

(a) Checks for message format errors

Verification of the message header, abbreviated bulletin headers and the end of message designator indicates that the message is properly formatted and complete, and contains the desired type of report.

- (1) Determine that the correct beginning (ZCZC) and end (NNNN) groups are present in the message.
- (2) Determine that at least one correct bulletin (SO) abbreviated header is present in the message.
If any of the above fields are incorrect or missing, visual inspection and subsequent correction is required.

(b) Check for coding errors

Coding errors are errors in the position or content of those fields or characters which are used to indicate the type, origin, and content of the report as opposed to errors in the physical values in the report.

- (3) Check that each report in a bulletin begins with JJXX or KKXX and terminates with a valid call sign or buoy number and "=". A missing or invalid call sign should be replaced with "SHIP". A list of valid call signs for ships reporting BATHY/TESAC should be used for this test.
- (4) Check that position 5 of the time group (group 3) is a "/". If the value is numeric, the report should be inspected to determine that the units of temperature and depth are in degrees Celsius and metres. Only then should the character be replaced with "/" and the message used. Otherwise, conversion to metric units should be effected, or the message should not be used.
- (5) If the report is a BATHY (JJXX) check that an 8888k group is present. This group must be in position 6 or 8 in the report.
- (6) If the report is a BATHY, check that the 999xx groups are increasing. (99901, 99903, etc.).
- (7) If the report is a TESAC (KKXX), check that a valid 888k₁k₂ group is present where k₁ can be 7 or 8 and where k₂ can have the value 0 through 3 inclusive. The group must be in position 6 or 8 of the report.

- (8) If the report is a TESAC, check that the sequence 2.3.4 or 2.3 is correct in the report for the depth-temperature-salinity portion of the message. If the 2.3 sequence only is present, the value of k_2 must be zero.
- (9) Check that the report does not contain any special characters after the "/" in the time field. Check also that, exclusive of the JJXX or KKKX designators and the call sign or buoy identifier, all other fields contain 5 character, numeric groups.
- (10) The quadrant should be 1, 3, 5 or 7.

If any of the above coding checks detect an error, visual inspection and subsequent correction should follow. If the value of k_2 in check 7 above is incorrect, then k_2 should be set to zero if salinity is not recorded. k_2 should be set to "2" if salinity is present and the proper value cannot be determined.

If in a report a coding error cannot be corrected, the report should be deleted.

(c) Check for physical errors

Physical errors include those such as erroneous position, depth, time, temperature, or salinity values.

- (11) Check the date and time groups in the report. The date should be valid and be the same as the bulletin date or before the bulletin date. The check should include number of days in the actual month of observation, and it should take leap years into account. If the date is more than 30 days before the bulletin date, an error should be suspected and the report should be inspected and compared with the reports from the same ship and, if necessary, corrected. The time group should have a value between 0000 and 2359.
- (12) Check the position fields of latitude and longitude. The latitude and longitude fields should be in the range 0000 to 9000 and 00000 to 18000, respectively. The minutes position should have a value less than, or equal to, 59. A time distance check should also be applied between successive reports from the same ship. If the ship could not have traveled the distance between the observations assuming a speed of 36 knots, then the time, date, and position fields should be further investigated for errors. If the maximum speed of the reporting vessel is known, it should be used in lieu of 36 knots.
- (13) The depth value for both BATHY and TESAC messages should be verified to be in the range 0000 to 9999 metres. All values of depth within a report should be checked to be sequentially increasing. Two equal values of depth are not permitted. Computer algorithms automatically encoding reports should average the values found if more than one significant point is found within one metre.

- (14) The sea temperature should be checked to be in the range -2.4°C to 35°C . There should also be a temperature spike test and gradient test (first and last depths only) applied to the data. A sample algorithm follows. National Centres are encouraged to use other formulae or tolerance values if the given scheme is not appropriate to local oceanographic conditions.

Sample Temperature Spike Test

$$\left| T_m - \frac{T_{m+1} + T_{m-1}}{2} \right| - \left| \frac{T_{m-1} - T_{m+1}}{2} \right| > \Delta T$$

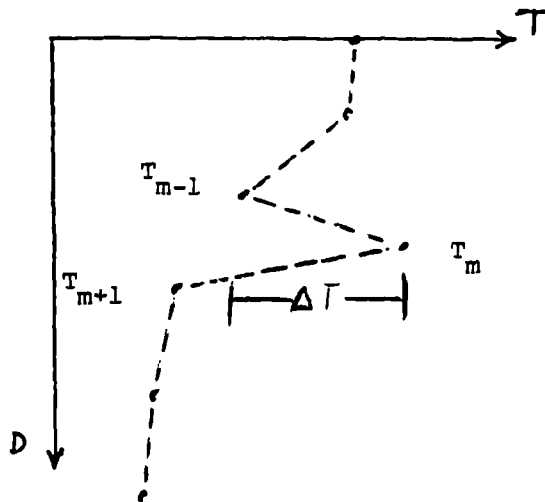

Temperature Gradient Test

$$\begin{aligned} |T_0 - T_1| &> 3^{\circ}\text{C} \\ \text{or } |T_{n-1} - T_n| &> 4^{\circ}\text{C} \end{aligned}$$

$\Delta T = 2.0^{\circ}\text{C}$ permitted tolerance.

- (15) The salinity value should be checked to be in the range 0‰ to 40‰ . It should be realized that the TESAC message does not distinguish between the old and practical salinity scales. A salinity spike test and gradient test (first and last depths only) should also be applied to the data. A sample algorithm follows. National Centres are encouraged to use other formulae or tolerance values if the given scheme is not appropriate to local oceanographic conditions.

Sample Salinity Spike Test

$$\left| S_m - \frac{S_{m+1} + S_{m-1}}{2} \right| - \left| \frac{S_{m-1} - S_{m+1}}{2} \right| > \Delta S$$

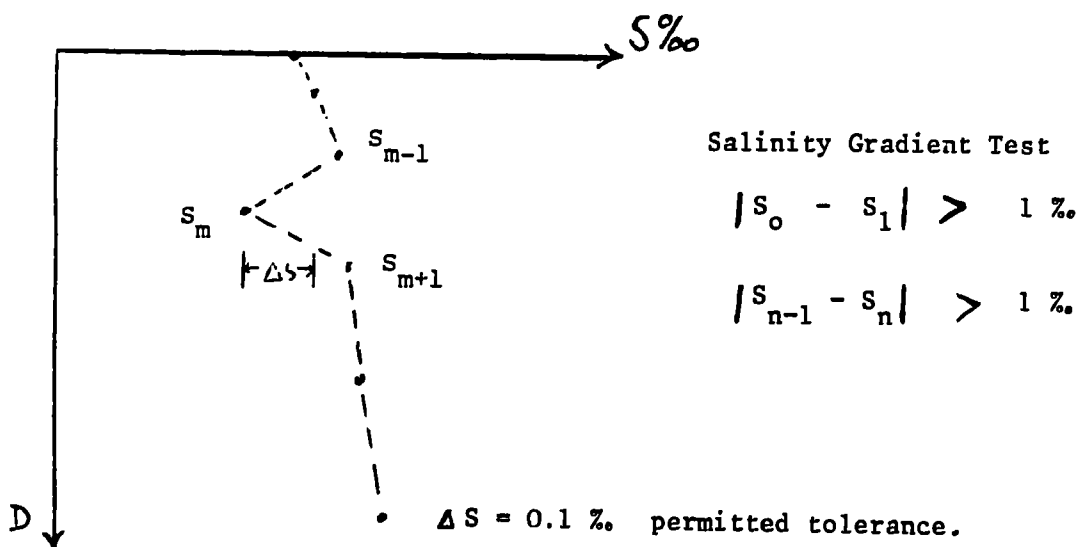

(16) The optional meteorological parameters should be checked to be within the ranges given below.

- $40 \leq$ air temperature $\leq 40^\circ\text{C}$
- 0 \leq wind direction ≤ 36
- 0 \leq wind velocity ≤ 50 knots (note that moored automated buoys may provide data in much higher wind conditions)

For all the above checks for physical errors, detection of a suspicious or erroneous value should result in visual inspection of the report. If necessary, other available reports from the same ship should be utilized to determine whether or not subsequent correction is possible. Corrections should only be made if it is considered highly likely that the value to be substituted is correct. For example, a ten degree error in latitude, a one month error in date or a ten degree error in temperature, in many situations, can be repaired with considerable confidence.

In all cases, the appropriate flag should be attached to each physical value to indicate whether or not quality control was carried out, the results of that quality control and, finally, to document changed or substituted physical values.

Duplicates check

In all cases, a check for duplicate reports should be carried out to eliminate statistical biases which would arise in products incorporating the same report more than once. The distinction between an exact and an inexact duplicate should be kept in mind. An exact duplicate

is a report in which all the physical variable groups (including space-time coordinates) are identical to those of a previous report of the same type (BATHY or TESAC) from the same ship. An inexact duplicate will have at least one difference.

Identification of duplicates should be carried out using both date-time call sign and area-time coincidences. If a duplicate so identified is an exact match, then one report is immediately eliminated.

If the match is inexact, then the abbreviated bulletin header must be examined to determine the action. If there is a three character field in the abbreviated header following the international date time group with the value "COR" then the duplicate is a correction to a previous report, and should replace that previous report.

However, if the abbreviated header does not contain the "COR" field, both reports should be retained and the second should be flagged as a duplicate. To accomplish this, it must be realized that processing, exchange, dissemination and archival systems associated with these data will have to carry a flag, as yet undefined, at the report level.

B. List of quality control flags

0. No quality control (QC) has been performed on this element.
1. QC has been performed: element appears to be correct.
2. QC has been performed: element appears to be inconsistent with other elements.
3. QC has been performed: element appears to be doubtful.
4. QC has been performed: element appears to be erroneous.
5. The value has been changed as a result of QC.
6. Reserve.
7. Reserve.
8. Reserve.
9. The value of the element is missing.

C. The following is a list of common physical errors:

- concerning date/time

Year not actual year
Month not actual month
Month exceeds 1-12

- concerning position
 - quadrant not 1, 3, 5, 7
 - latitude and longitude interchanged
 - latitude and longitude not within appropriate limits

- concerning depths
 - depths not increasing
 - depths repeated

- concerning temperature/salinity
 - temperature/salinity exceeding reasonable limits
 - spikes in temperature/salinity readings.

GUIDELINES FOR REPORTING MONTHLY BATHY / TESAC STATISTICSIntroduction

IGOSS statistics are to be reported using the
IGOSS STATISTICAL EVALUATION SHEET
(see Annex VII, page 3).

A nationally designed reporting form containing at least the same information as the IGROSS SHEET is acceptable.

The exchange statistics report should be submitted as soon after the end of each month as possible (within two weeks) to assure rapid feedback of information. Statistics are based upon individual reports of observations encoded in the appropriate code form (BATHY reports are in WMO code form FM 63-VI and TESAC reports in WMO code form FM 64-VI).

Please note that each BATHY or TESAC bulletin (which is usually identified by SO in the TTA₁A₂ii group of the abbreviated heading, see Annex III and IV) may contain more than one report. Any additional information which would be useful in evaluating exchange, such as the number of garbled messages or problems in the exchange process, should be included with the monthly report.

The BUOY section of the statistical evaluation sheet is not used presently. Specific guidelines on the use of this section will be formulated later.

GUIDELINES

NATIONAL CENTER: Enter the name of the meteorological or
and oceanographic center providing IGROSS
statistics on the number of BATHY and TESAC
COUNTRY: reports INPUT and OUTPUT onto the GTS.

Each country should submit only
one Evaluation sheet.

MONTH: Enter the calendar month and year for
and which statistics are provided.
YEAR Statistics should be compiled by counting
those reports whose bulletin date/time
group falls within the given month,
i.e. the date/time group of the bulletin
should be between 0000 on the first
of the month and 2400 on the last
day of the month.

INPUT:

Indicate separately the total number of BATHY and TESAC reports entered into the GTS by the country submitting the evaluation sheet.

All reports input should be counted on the evaluation sheet regardless of the country of registry of the originating ship.

If quality-control procedures are performed on reports prior to input, only those reports which are actually input onto the GTS should be counted.

When it is discovered that two or more countries are entering the same reports, arrangements should be made so that the reports are entered only once.

OUTPUT

Indicate separately the total number of BATHY and TESAC reports received from the GTS by the country submitting the report evaluation sheet.

The number of reports should be indicated individually by originating GTS counter.

Reports from repeated bulletins (those arriving at a center more than once or via different routes) should not be counted.

If any duplicates are discovered within the output, they should be listed within parenthesis next to the output as well as included in the output.

All output reports should be counted even if they are not utilized by the receiving center.

The following is an example of a completed
IGOSS STATISTICAL EVALUATION SHEET:

IGOSS STATISTICAL EVALUATION SHEET

NATIONAL CENTRE: Walton ville

MONTH: April

COUNTRY: Republic of Gondwana

YEAR: 1980

INPUT

Data input consists of all data collected from coastal radio stations and entered onto the GTS

GTS centre	BATHY	TESAC	BUOY
CSPU	427	386	
<u>OUTPUT</u>			
Data <u>output</u> consists of all data received by the telecommunication centre from other GTS centres			
GTS centre	BATHY	TESAC	BUOY
LWHF	77 (6)	84 (4)	
CYPF	55 (7)	23 (0)	
DIWN	26 (2)	15 (0)	
DEMS	462 (12)	315 (20)	
EGRR	200 (15)	45 (10)	
ESWI	45 (2)	15 (10)	
KWBC	1100 (20)	25 (2)	
LFPW	42 (2)	16 (1)	
RJTD	475 (26)	35 (0)	
RUHB	216 (10)	300 (12)	
RUMS	400 (20)	750 (6)	
RUML	275 (6)	300 (40)	
SABM	25 (0)	10 (0)	
Total output	3398	1933	

Note: The number in parenthesis indicate the number of duplicates within the total from that GTS centre.

Repeated bulletins are not counted.

List of Abbreviations

A X B T	Airborne Expendable Bathythermograph
B A T H Y	Bathythermographic observation
B T	Bathythermograph (mechanical)
C T D	Conductivity - Temperature - Depth instrument
D C P	Data Collecting Platform
D N A	Designated National Agency
G E K	Geomagnetic Electrokinetograph
G T S	Global Telecommunication System (of WMO)
I D P S S	IGOSS Data Processing and Services System
I G O S S	Integrated Global Ocean Services System
I O C	Intergovernmental Oceanographic Commission
I O D E	International Oceanographic Data Exchange
I O S	IGOSS Observing System
M T C	Main Trunk Circuit (of GTS)
N O C	National Oceanographic Centre (IGOSS)
N O D C	National Oceanographic Data Centre (IODE)
N M C	National Meteorological Centre
O B S	Indicator for paid service (in BATHY and TESAC radio messages)
O S V	Ocean Station Vessel
O W S	Ocean Weather Station
R N O D C (IGOSS)	Responsible National Oceanographic Data Centre (for IGOS)
R T H	Regional Telecommunication Hub (of GTS)
S O C	Specialized Oceanographic Centre (IGOSS)
S T D	Salinity - Temperature - Depth instrument
T E S A C	Temperature - Salinity - Current observation
V O S	Voluntary Observing Ships (of WMO)

W M O	World Meteorological Organization
W O C	World Oceanographic Centre (IGOSS)
W W W	World Weather Watch (of WMO)
X B T	Expendable Bathythermograph
X C T D	Expendable Conductivity - Temperature - Depth instrument
X S T D	Expendable Salinity - Temperature - Depth instrument